

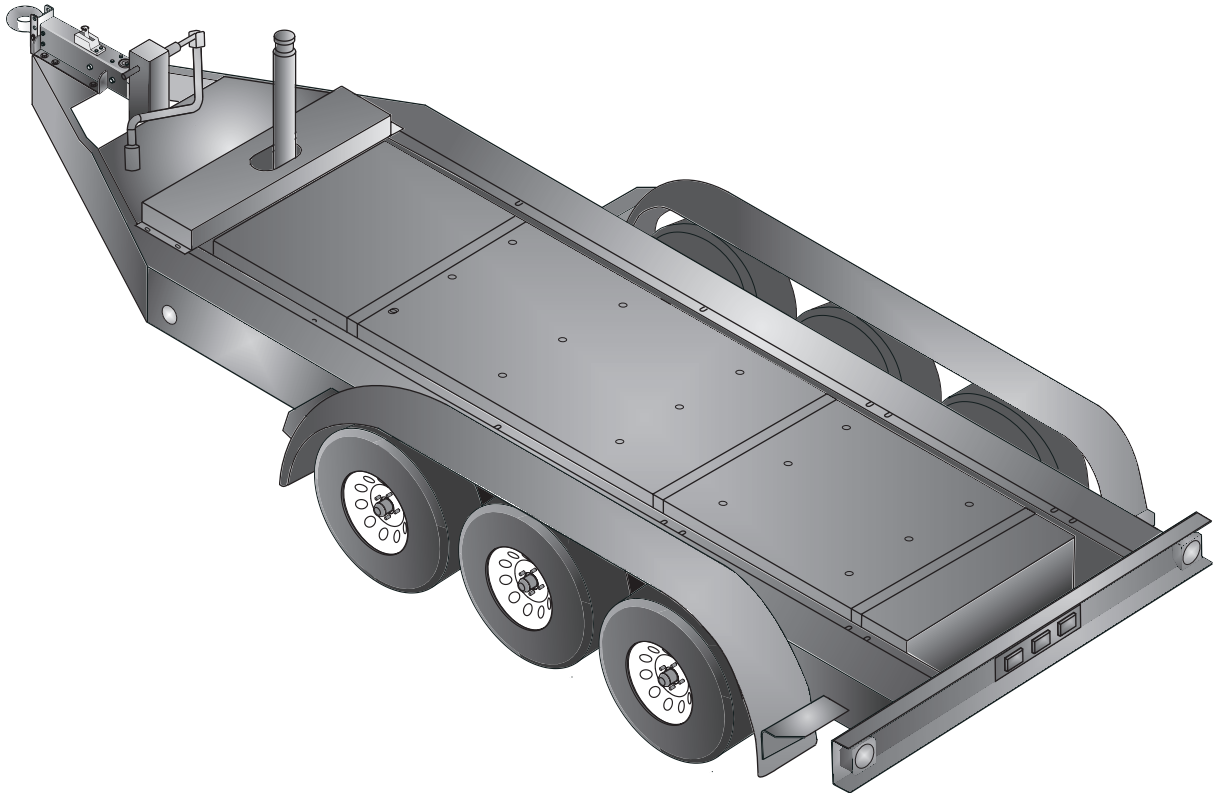

TRLR400XF3DA

MQ POWER Triple Axle Trailer



TRLR400XF3DA Technical Data

Gross Vehicle Weight Rating (GVWR) — 20,000 lbs (9,072 kg)	Tire Size — ST235/80R16 LR-E
Gross Axle Weight Rating (GAWR) — 7,000 lbs (3,175 kg) (ea.)	Wheel Bolt Pattern — 8 x 6.5
Actuator Rating — 20,000 lbs (9,072 kg)	Tire Load Rating — 3,500 lbs (1,588 kg) ea.
Coupler Rating — See coupler options on back page	Dimensions — See reverse page

STANDARD TRAILER EQUIPMENT

- Fits MQ Power Generator Model DCA400SSI4F
- Triple Drop-Axle Design with Slipper Spring Suspension
- Formed Steel Channel Frame Construction
- Integral Diesel Fuel Cell; Single-wall Steel Design, 350-gallon/1,325-liter Capacity; UN31A Certified
- Replaceable, Bolt-on Hydraulic Brake Actuator
- Hydraulic Uni-servo Drum Brakes with free backing 12-inch Cluster
- D.O.T. Steel Brake Lines, Brass Tees & Rubber Hydraulic Brake Hoses
- 4-hole Channel Allows 3-position, Adjustable Coupler Height; 4-inches O/A
- Heavy-duty Tongue Mounted, Drop-leg Jack (rated 10,000 pound lift)
- Replaceable Bolt-on Steel Fenders
- High-gloss Enamel Coated Frame, Channel, Actuator and Fenders
- D.O.T. Approved Tail Lamps, Stop Lamps, Turn Signal Lamps, Side Marker Lamps
- Weatherproof, Rubber Armored, 2-piece Trailer Light Wiring Harness



TRLR400XF3DA

MQ POWER Triple Axle Trailer

OPTIONAL TRAILER EQUIPMENT

- Adjustable 2 5/16-inch Ball Coupler
- Adjustable 3-inch Pintle Eye Coupler
- Rear Stabilizer Stands
- Tongue Mounted Utility Storage Box
- Spare Tire with Locking Mount
- Anti-Theft Wheel Lock
- Electric-Actuated Drum Brakes (all axles)

Coupler Options

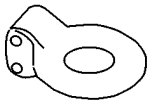
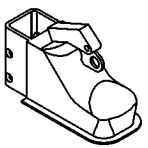
3" Pintle Eye 25,000 lbs. #EE36264	
2-5/16" Ball Coupler 20,000 lbs. #EE56770	

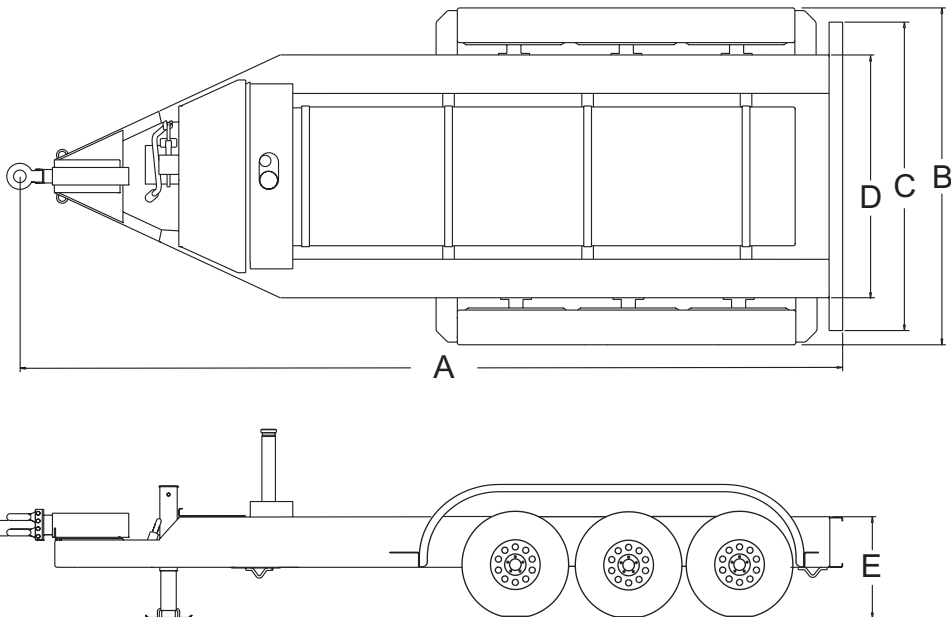

Trailer Dimensions						
A	B	C	D	E	F	
					Min	Max
264 in.	94 in.	84 in.	66 in.	27.4 in.	22.6 in.	26.6 in.

Trailer Weight	
Without Fuel	With Fuel
4,280 lbs. (1,943 kg)*	6,765 lbs (3,071 kg)*

*Weight is approximate

Your Multiquip dealer is:

