

THIS DRAWING AND THE DATA DISCLOSED HEREIN OR HEREWITH IS CONFIDENTIAL AND PROPRIETARY AND IS NOT TO BE REPRODUCED, USED, OR DISCLOSED IN WHOLE OR IN PART TO ANYONE WITHOUT THE EXPRESSED WRITTEN PERMISSION OF MULTIQUIP COMPANY.

| | | | | | | | |
|----------|-----|-------------|------|----------|--|--|--|
| Dwg. No. | | 202042 | | REVISION | | | |
| ZONE | LTR | DESCRIPTION | DATE | APPROVED | | | |
| | | | | | | | |

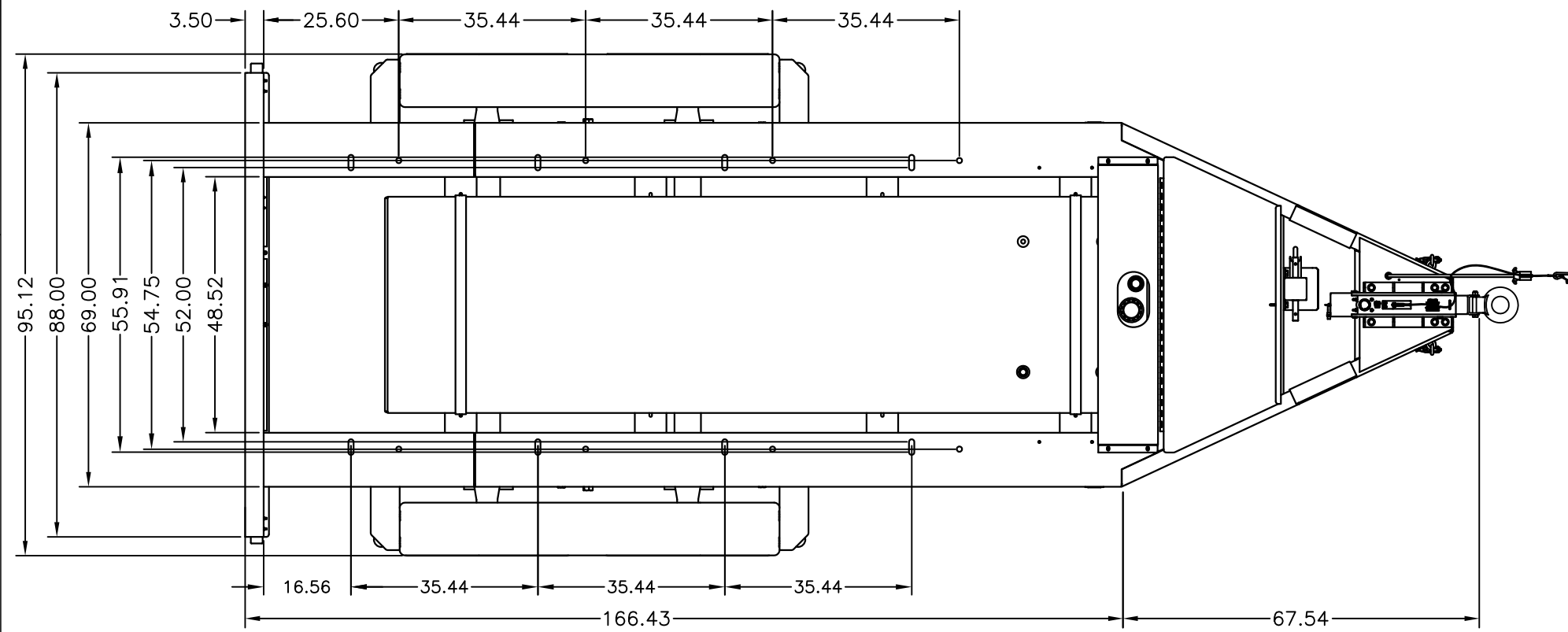

| HITCH OPTIONS | |
|--|--|
| 3' ADJUSTABLE EYE 25,000lbs (EE36264 - PRIMED) | |

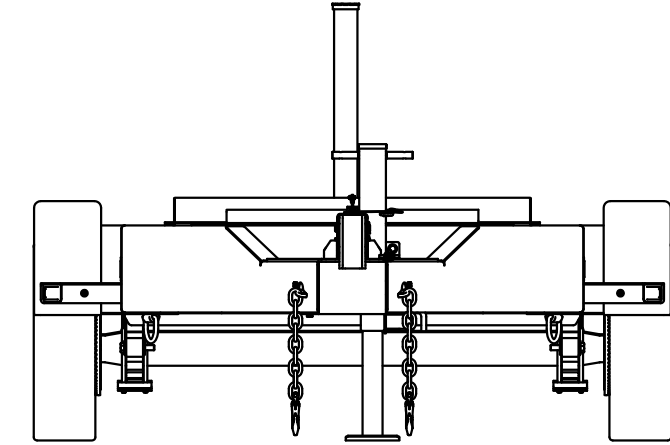
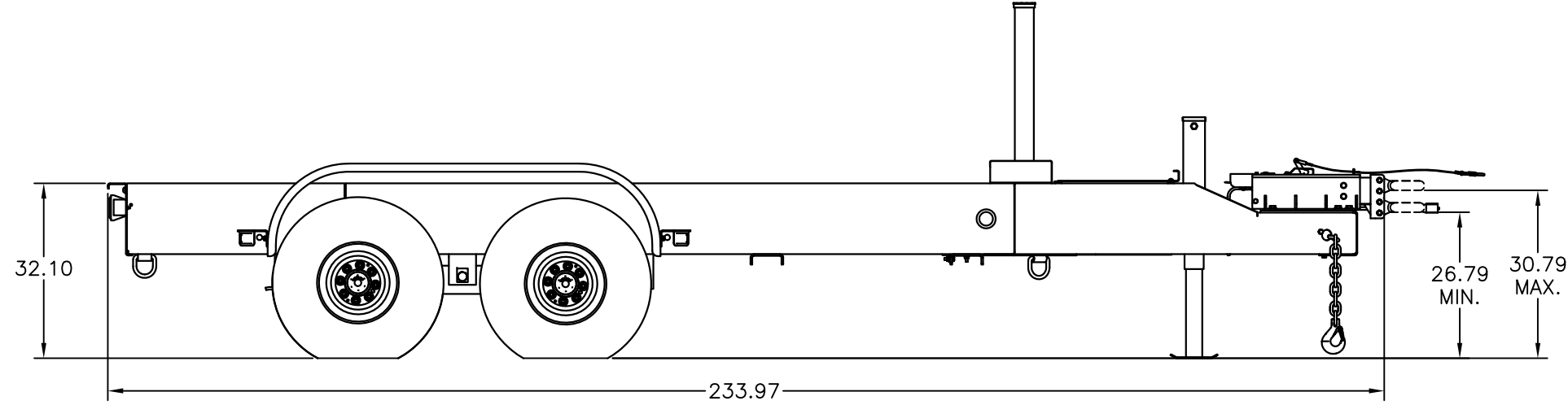

| TRLR325XF HYDRAULIC BRAKES TRAILER | |
|------------------------------------|----------------------------------|
| WEIGHT | 3760lbs |
| LENGTH | 234" |
| WIDTH | 95" |
| FRAME WIDTH | 69" |
| AXLE | 10,000lbs (QTY 2) DEXTER AXLE |
| TIRES | 235/75R17.5 "J", 6005lbs (QTY 4) |
| WHEELS | 17.5 X 6.75 (QTY 4) |
| GVWR | 18,000lbs |
| JACK | 10K HEAVY DUTY DROPLEG JACK |
| FUEL TANK | 300GAL. CAPACITY (UN31A) |

| | | | | | |
|--|----------------------|------------------|----------|---|--------------------|
| UNLESS OTHERWISE SPECIFIED DIMENSIONS ARE IN INCHES TOLERANCES ARE : | | CUSTOMER | | MQ POWER TEL: (310) 537-3700/FAX: (310) 632-2656 18910 WILMINGTON AVENUE CARSON, CA 90746 | |
| FRACTIONS | DECIMALS | ANGLES | JOB NO. | | |
| ± | .XX ± | ± | | | |
| | .XXX ± | | | | |
| DERIVED FROM 201702 | MATERIAL | APPROVALS | DATE | TRLR325XF HYD. BRAKES TRAILER G.V.W.R.: 18,000lbs | |
| REV | FINISH | DRAWN J. TRAN | 12/11/14 | SIZE D | FSCM NO. |
| CAD CODE 202042 | DO NOT SCALE DRAWING | CHECKED | | SCALE 1/14 | DWG. NO. 202042 |
| | | SALESMAN | | SHEET 1 / 1 | |

Dwg. No. 202042

REVISION

A