

THIS DRAWING AND THE DATA DISCLOSED HEREIN OR HEREWITH IS CONFIDENTIAL AND PROPRIETARY AND IS NOT TO BE REPRODUCED, USED, OR DISCLOSED IN WHOLE OR IN PART TO ANYONE WITHOUT THE EXPRESSED WRITTEN PERMISSION OF MULTIQUIP COMPANY.

DWG. NO. 201700 REVISION A 1

REVISIONS				
ZONE	LTR	DESCRIPTION	DATE	APPROVED
A		REPLACED FRAME EE55308 WITH EE56589	09/14/12	JT

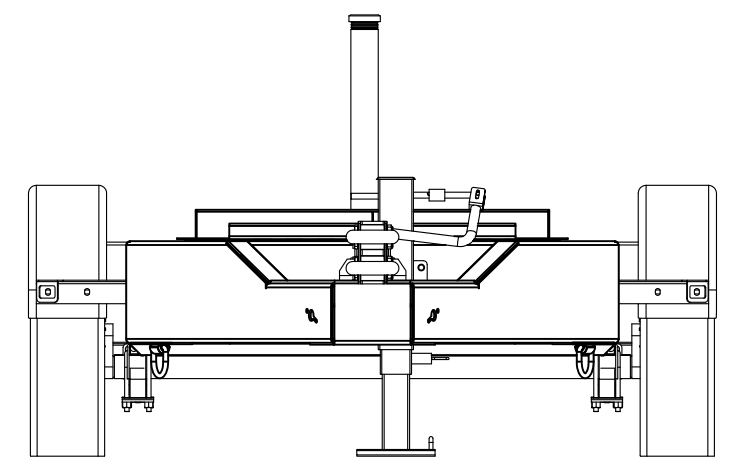
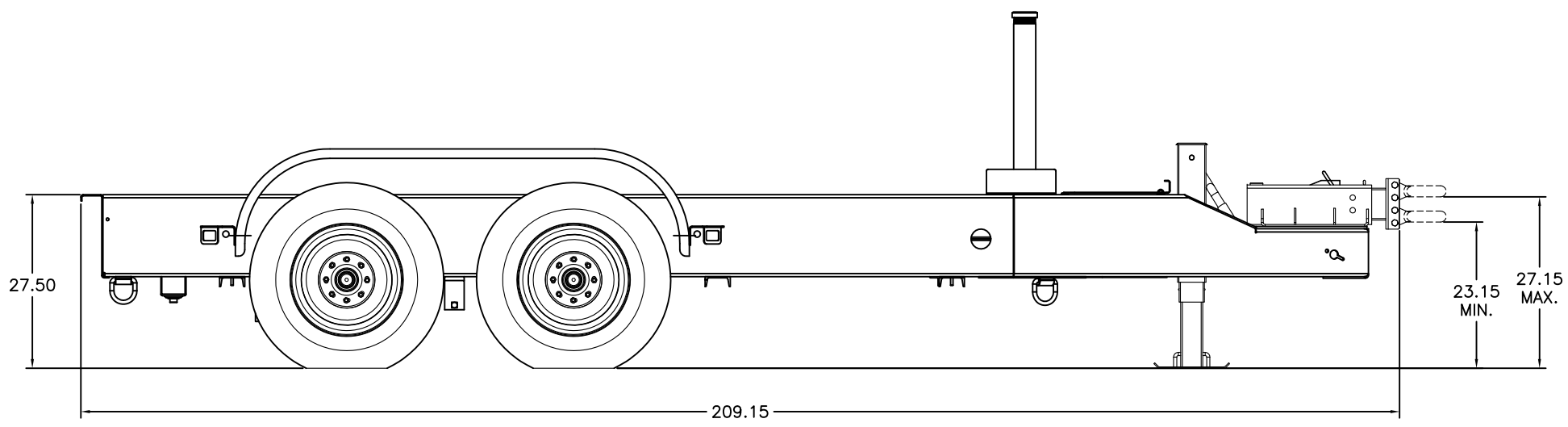
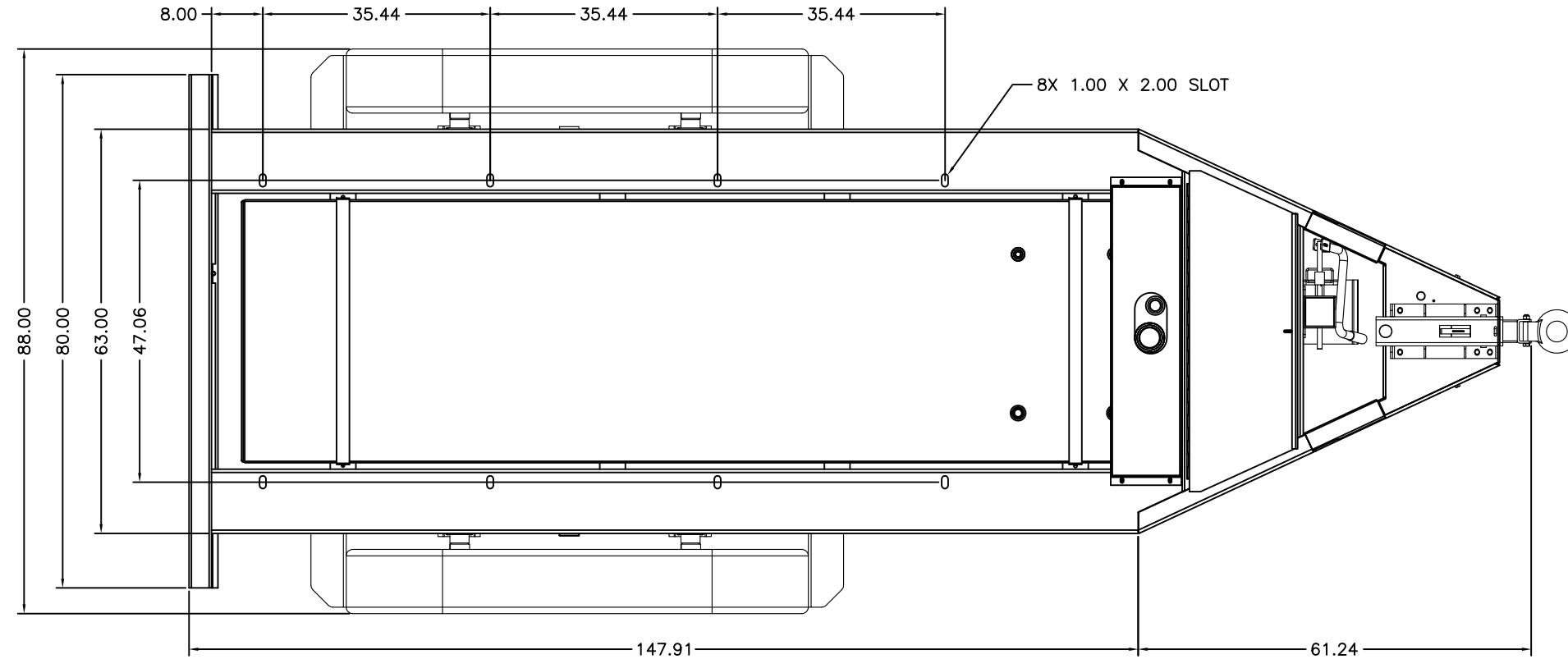

TRLR220XF HYDRAULIC BRAKES TRAILER	
WEIGHT	2,761lbs
LENGTH	209"
WIDTH	88"
FRAME WIDTH	63"
AXLE	7000lbs (QTY 2) DEXTER AXLE
TIRES	ST235/80R-16 LR-E 3500# (QTY 4)
WHEELS	16 X 6
GVWR	13,500lbs
JACK	10K HEAVY DUTY JACK
HITCH	3" ADJUSTABLE EYE (OPTIONAL)
FUEL TANK	300GAL. (CAPACITY)

UNLESS OTHERWISE SPECIFIED DIMENSIONS ARE IN INCHES TOLERANCES ARE :		CUSTOMER		MQ POWER TEL: (310) 537-3700/FAX: (310) 632-2656 18910 WILMINGTON AVENUE CARSON, CA 90746	
FRACTIONS	DECIMALS	ANGLES	JOB NO.		
±	.XX ±	±			
	.XXX ±				
DERIVED FROM		MATERIAL		TRLR220XF HYD. BRAKES TRAILER	
REV	DATE	FINISH		G.V.W.R.: 13,500lbs	
A	09/14/12	DO NOT SCALE DRAWING		SALESMAN	
CAD CODE 201700		SCALE		FSCM NO. DWG. NO. SHEET	
		1/12		201700 1 / 1	

DWG. NO. 201700 REVISION A