

THIS DRAWING AND THE DATA DISCLOSED HEREIN OR HERewith IS CONFIDENTIAL AND PROPRIETARY AND IS NOT TO BE REPRODUCED, USED, OR DISCLOSED IN WHOLE OR IN PART TO ANYONE WITHOUT THE EXPRESSED WRITTEN PERMISSION OF MULTIQUIP COMPANY.

DWG. NO.	201698	REVISION		
REVISONS				
ZONE	LTR	DESCRIPTION	DATE	APPROVED

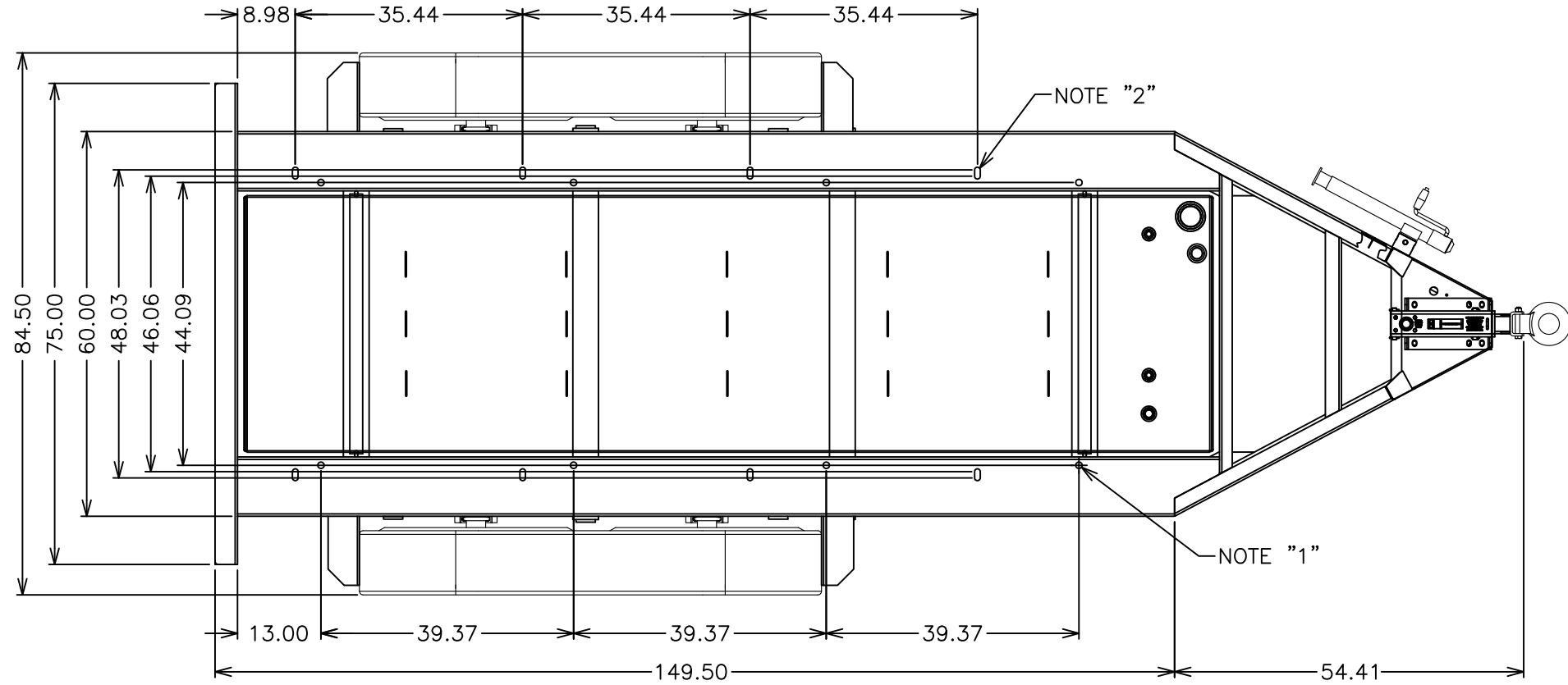

HITCH OPTIONS	
3" ADJUSTABLE EYE 20,000lbs (EE36264 - PRIMED)	
2-5/16" BALL COUPLER 14,000lbs (EE43253 - PLATED)	

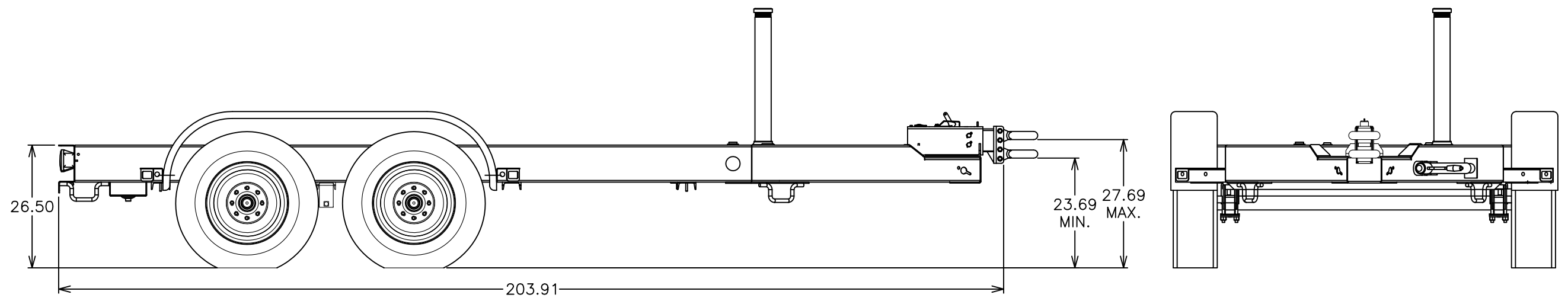

TRLR180XF HYDRAULIC BRAKES TRAILER	
WEIGHT	2,580lbs
LENGTH	204"
WIDTH	84.5"
FRAME WIDTH	60"
AXLE	7000lbs (QTY 2) DEXTER AXLE
TIRES	ST235/80R-16 LR-E 3500lbs (QTY 4)
WHEELS	16 X 6 (QTY 4)
GVWR	12,000lbs
JACK	CEQUENT, 5000lbs (QTY 1)
FUEL TANK	210GAL. CAPACITY
HITCH	SEE TABLE FOR OPTION

NOTES:
 1. MOUNTING FOR DCA150SSI/150SSJU3.
 2. MOUNTING FOR DCA150SSCU/180SSCU/180SSI/180SSJU.

UNLESS OTHERWISE SPECIFIED DIMENSIONS ARE IN INCHES TOLERANCES ARE :		CUSTOMER		MQ POWER	
FRACTIONS	DECIMALS	ANGLES	JOB NO.	TEL: (310) 537-3700/FAX: (310) 632-2656	
±	.XX ±	±	APPROVALS	18910 WILMINGTON AVENUE	
	.XXX ±		DATE	CARSON, CA 90746	
DERIVED FROM	MATERIAL	DRAWN	J. TRAN	TRLR180XF HYD. BRAKES TRAILER	
REV	DATE	CHECKED	01/20/12	G.V.W.R.: 12,000lbs	
CAD CODE	DO NOT SCALE DRAWING	SALESMAN		SIZE	FSCM NO.
201698				D	201698
				SCALE	DWG. NO.
				1/12	201698
					SHEET
					1 / 1

DWG. NO. 201698

SHEET