

THIS DRAWING AND THE DATA DISCLOSED HEREIN OR HEREWITH IS CONFIDENTIAL AND PROPRIETARY AND IS NOT TO BE REPRODUCED, USED, OR DISCLOSED IN WHOLE OR IN PART TO ANYONE WITHOUT THE EXPRESSED WRITTEN PERMISSION OF MULTIQUIP COMPANY.

| PART LISTS |                        |     |  |             |
|------------|------------------------|-----|--|-------------|
| ITEM       | PART NUMBER            | QTY | DESCRIPTION  | MANUFACTURE |
| 1          | DCA125SSIU4F (TIER 4F) | 1   | 125KVA GENSET<br>125SSIU4F GENSET WEIGHT (DRY): 5,286bs  | MQ POWER    |
| 2          | TRLR125USH             | 1   | TRAILER (MODEL: TRLR125USH)<br>TRAILER WT. ONLY (APPROX.): 1,722lbs<br>G.V.W.R.: 10,000lbs<br>TONGUE WT.:<br>OVERALL DIMENSION: 181L X 79.5W X 90H | MQ POWER    |
| 3          | EE44774                | 4   | TIRE ST225/75D15 LR-D 2540lbs RATING<br>WHEEL 15 X 6   | TREDIT TIRE |
| 4          | EE56652                | 2   | HYDRAULIC TORSION AXLE, 5,000lbs RATING  | DEXTER AXLE |
| 5          | EE43518                | 1   | JACK, 5K   | CEQUENT     |
| 6          |                        | 1   | SEE HITCH OPTION TABLE   |             |

| HITCH OPTIONS   |   |
|---|---|
| 3' ADJUSTABLE EYE<br>20,000lbs<br>(EE36264 - PRIMED)    |  |
| 2-5/16" BALL COUPLER<br>14,000lbs<br>(EE43253 - PLATED) |  |

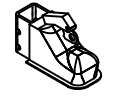
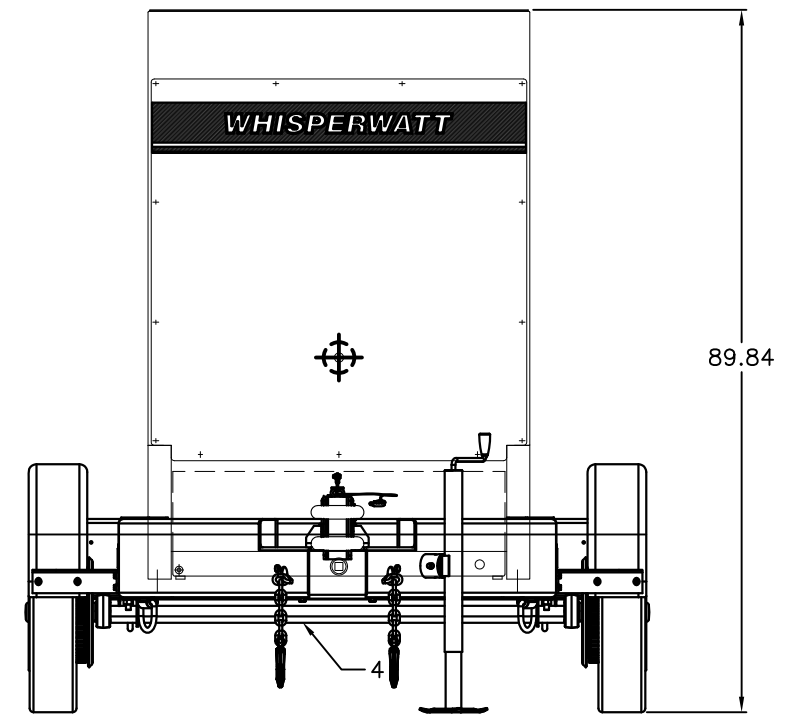
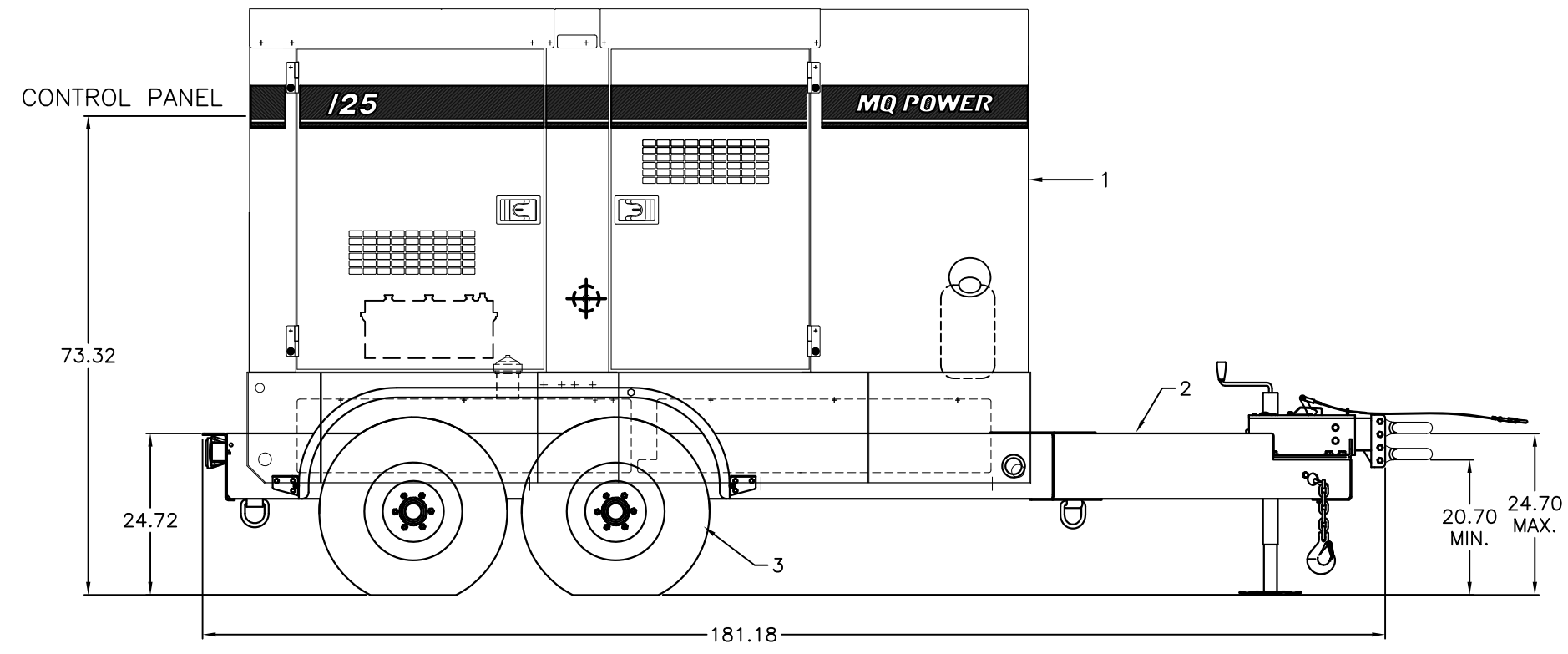
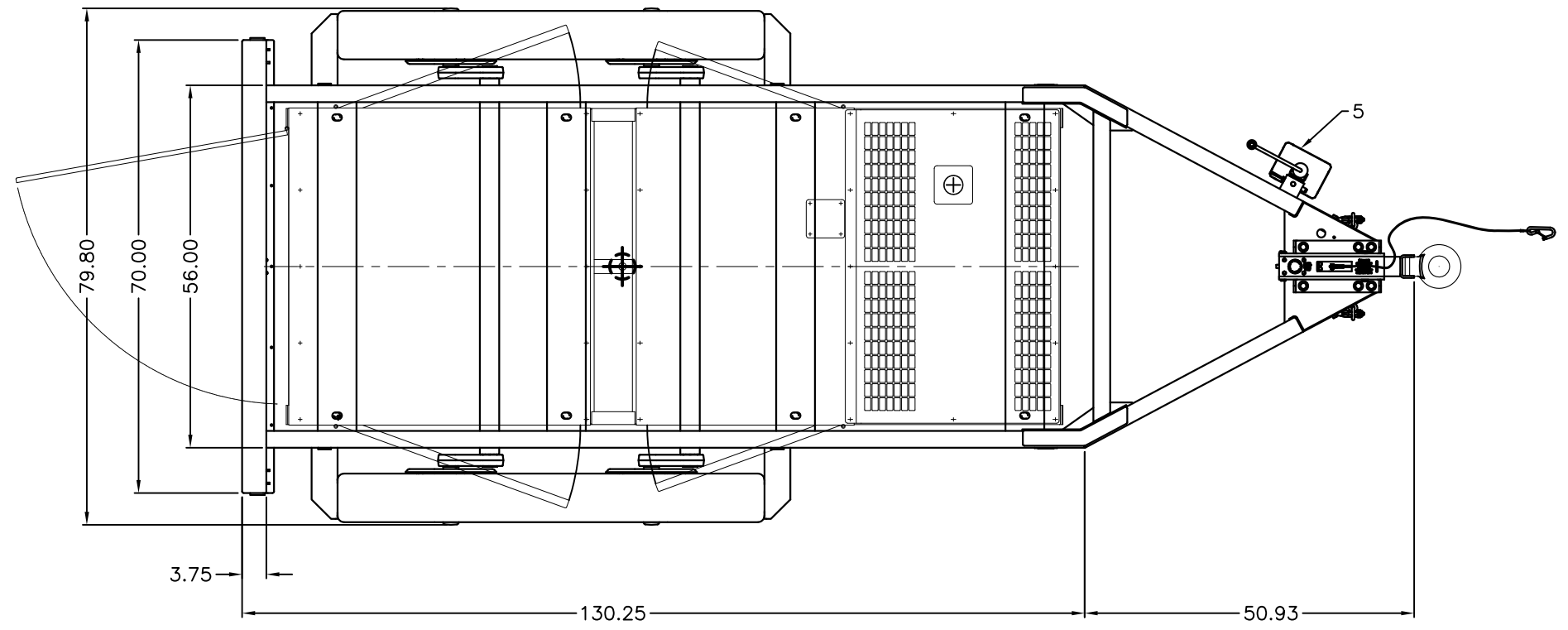

|  |          |                      |                     |   |                               |          |
|--|----------|----------------------|---------------------|---|-------------------------------|----------|
| UNLESS OTHERWISE SPECIFIED DIMENSIONS ARE IN INCHES TOLERANCES ARE : |          | CUSTOMER             |                     | <b>MQ POWER</b><br>TEL: (310) 537-3700/FAX: (310) 632-2656<br>18910 WILMINGTON AVENUE<br>CARSON, CA 90746 |                               |          |
| FRACTIONS  | DECIMALS | ANGLES               | JOB NO.             |   |                               |          |
| ±  | .XX ±    | ±                    |                     | APPROVALS   |                               | DATE     |
|  | .XXX ±   |                      |                     | DRAWN   |                               |          |
| DERIVED FROM   |          | MATERIAL             |                     | J. TRAN   |                               | 03/10/15 |
| REV  | DATE     | FINISH               |                     | CHECKED   |                               |          |
| CAD CODE 202059  |          | DO NOT SCALE DRAWING |                     | SALESMAN  |                               |          |
|  |          |                      | DCA125SSIU4F GENSET |   | MTD ON TRLR125US HYD. TRAILER |          |
| SIZE   | FSCM NO. | DWG. NO.             |                     | SHEET   |                               |          |
| D  |          | 202059               |                     | 1 / 1   |                               |          |
| SCALE  |          |                      | 1/12                |   |                               |          |

DWG. NO. 202059